

## LEDs

3030 SMD – White

HL-9626

### Package Configuration

Descriptions:
Emitting Color: White
Device Outline: 3.0x3.0x0.65mm
Lens Type: Yellow Diffused

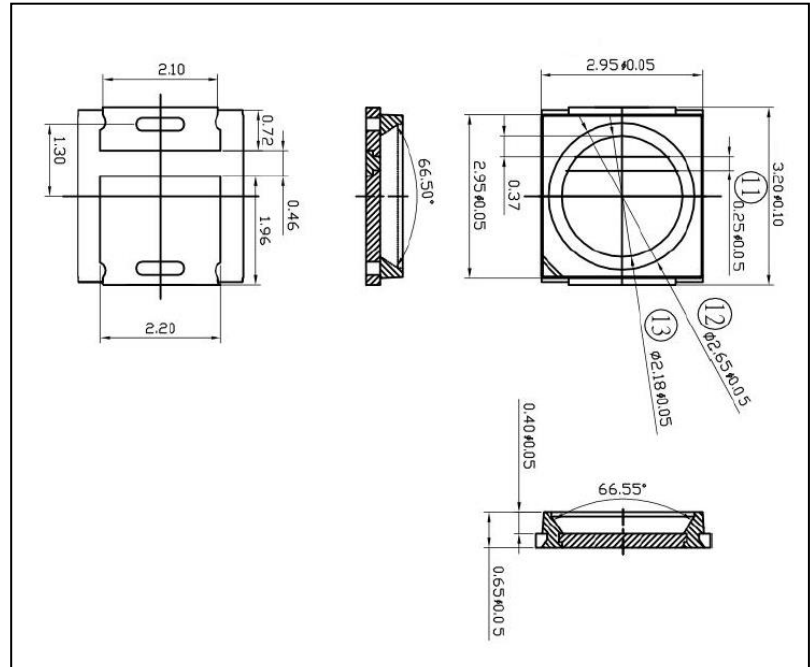

### Absolute Maximum Ratings (Ta=25°C)

Parameter	Max.	Unit.
Peak Forward Current (1/10 Duty Cycle, 0.1ms Pulse Width)	1000	mA
Continuous Forward Current	350	mA
Reverse Voltage	5	V
Storage/Operating Temperature Range	-40 °C to +85°C	
Power Dissipation	1W	
Lead Soldering Temperature[4mm(.157") From Body]	250°C for 5 Seconds	

### Electrical and optical characteristics

Parameter	Symbol	Min.	Typ.	Max.	Unit.	Test Condition
Luminous Intensity	$I_v$	-	142	-	lumens	$I_f=350mA$
Viewing Angle	$2\theta_{1/2}$	-	120	-	deg.	
Color Temperature	-	-	5000	-	K	