

## LEDs

### 5mm – RGB – Common Cathode

HL-9538

Descriptions:	
Emitting Color:	RGB
Device Outline:	Φ 5mm round type
Lens Type:	Water Clear

Pin	Function
1	Red
2	Common Cathode
3	Green
4	Blue

### Package Configuration

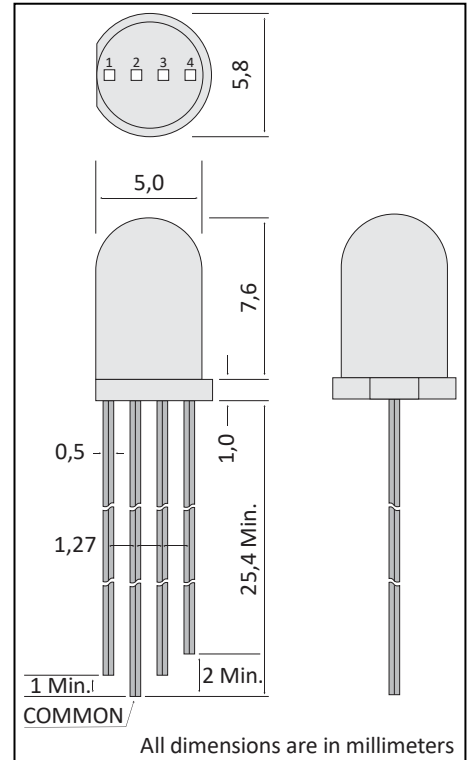

### Absolute Maximum Ratings (T<sub>a</sub>=25°C)

Parameter	Max.	Unit.
Peak Forward Current (1/10 Duty Cycle, 0.1ms Pulse Width)	100	mA
Continuous Forward Current	R=30 / G=25 / B=30	mA
Reverse Voltage	5	V
Storage/Operating Temperature Range	-40 °C to +85°C	
Power Dissipation	R=45 / G=56 / B=60 (mW)	
Lead Soldering Temperature[4mm(.157") From Body]	250°C for 5 Seconds	

### Electrical and optical characteristics

Parameter	Symbol	Typ.	Unit.	Test Condition
Luminous Intensity	I <sub>v</sub>	R=1000 / G=1300 / B=500	mcd	I <sub>F</sub> = R=30 / G=25 B=30mA
Viewing Angle	2θ <sub>1/2</sub>	60	deg.	
Dominant Wavelength	λ <sub>d</sub>	R=630 / G=525 / B=465	nm	
Forward Voltage	V <sub>F</sub>	R=1.9 / G=3.3 / B=3.3	V	