

LEDs

5mm – Bicolor – Common Cathode

HL-9530

Package Configuration

Descriptions:	
Emitting Color:	Red / Green
Device Outline:	Φ 5mm round type
Lens Type:	Water Clear

Pin	Function
1	Red
2	Common Cathode
3	Green

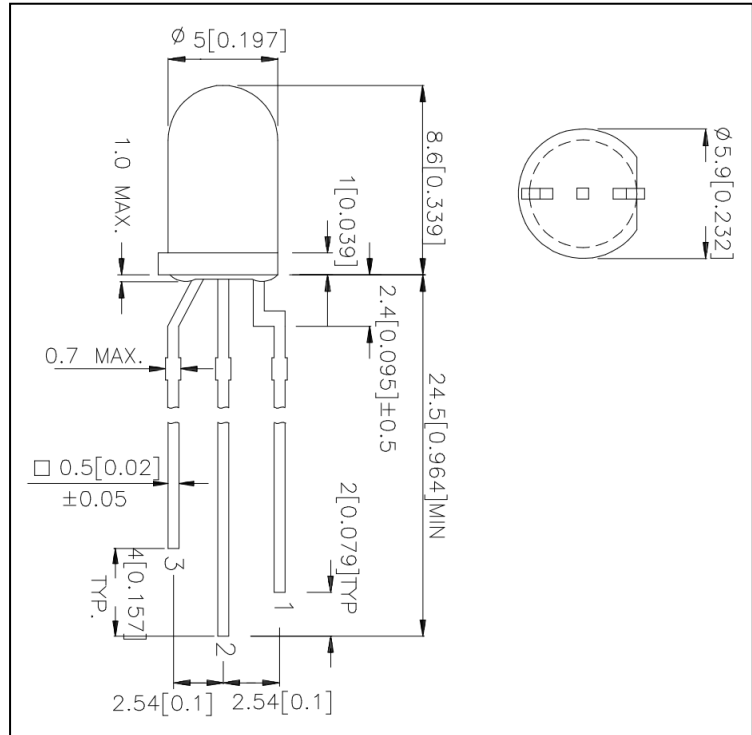

Absolute Maximum Ratings (T_a=25°C)

Parameter	Max.	Unit.
Peak Forward Current (1/10 Duty Cycle, 0.1ms Pulse Width)	100	mA
Continuous Forward Current	R=20 / G=20	mA
Reverse Voltage	5	V
Storage/Operating Temperature Range	-40 °C to +85°C	
Power Dissipation	R=45 / G=56 / B=60 (mW)	
Lead Soldering Temperature [4mm (.157") From Body]	250°C for 5 Seconds	

Electrical and optical characteristics

Parameter	Symbol	Typ.	Unit.	Test Condition
Luminous Intensity	I _v	R=200 / G=200	mcd	I _f = 20mA
Viewing Angle	2θ _{1/2}	70	deg.	
Dominant Wavelength	λ _d	R=625 / G=520	nm	
Forward Voltage	V _F	R=1.9 / G=3.3	V	