

## LEDs

### 5mm Round – Infrared

### HL-8060

#### Package Configuration

Descriptions:
Emitting Color: Infrared
Device Outline: $\Phi$ 5mm round type
Lens Type: Water Clear

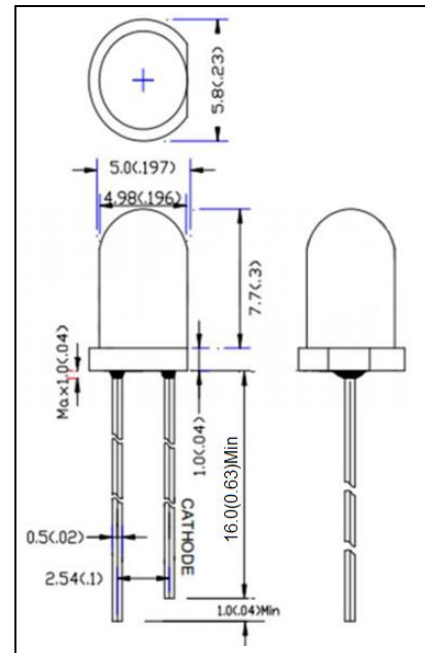

### Absolute Maximum Ratings (Ta=25°C)

Parameter	Max.	Unit.
Peak Forward Current (1/10 Duty Cycle, 0.1ms Pulse Width)	100	mA
Continuous Forward Current	20	mA
Reverse Voltage	5	V
Operating Temperature Range	-40 °C to +85°C	
Storage Temperature Range	-40 °C to +100°C	
Lead Soldering Temperature[4mm(.157") From Body]	250°C for 5 Seconds	

### Electrical and optical characteristics

Parameter	Symbol	Min.	Typ.	Max.	Unit.	Test Condition
Luminous Intensity	$I_v$	-	60	-	mW/cm <sup>2</sup>	$I_F=20mA$
Viewing Angle	$2\theta_{1/2}$	-	17	-	deg.	
Dominant Wavelength	$\Delta d$	-	940	-	nm	