

LEDs

3528 SMD Type

HL-7927

Package Configuration

Descriptions:
Material: AlGaAs
Emitting Color: Green
Device Outline: 3.5x2.8x1.9mm
Lens Type: Water Clear

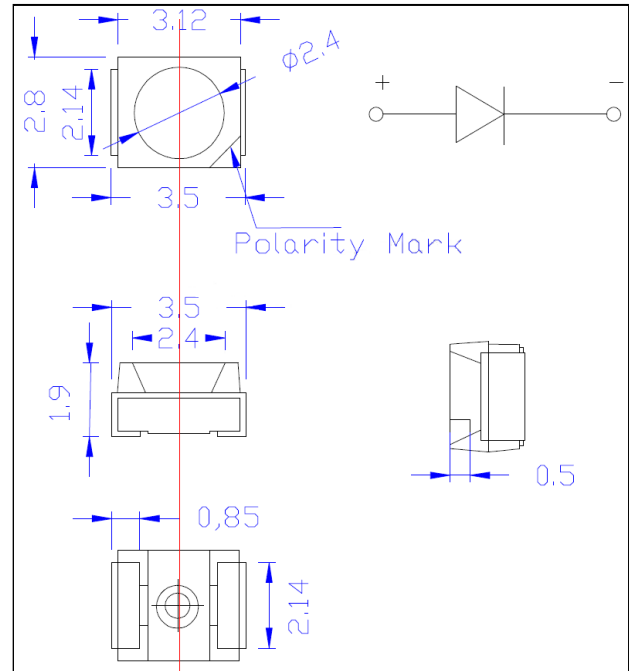

Absolute Maximum Ratings (Ta=25°C)

Parameter	Max.	Unit.
Peak Forward Current (1/10 Duty Cycle, 0.1ms Pulse Width)	100	mA
Continuous Forward Current	30	mA
Reverse Voltage	5	V
Operating Temperature Range	-40 °C to +85°C	
Storage Temperature Range	-40 °C to +100°C	
Lead Soldering Temperature[4mm(.157") From Body]	250°C for 5 Seconds	

Electrical and optical characteristics

Parameter	Symbol	Min.	Typ.	Max.	Unit.	Test Condition
Luminous Intensity	I_v	-	18	-	mcd	$I_f=20mA$
Viewing Angle	$2\theta_{1/2}$	-	120	-	Deg.	
Dominant Wavelength	Δd	-	570	-	nm	