

LEDs

3mm Bicolor Red/Green – Common cathode HL-7883

Package Configuration

Descriptions:	
Emitting Color: Red/Green	
Device Outline: Φ 3mm round type	
Lens Type: Water Clear	

Pin	Function
1	Anode Red
2	Common Cathode
3	Anode Green

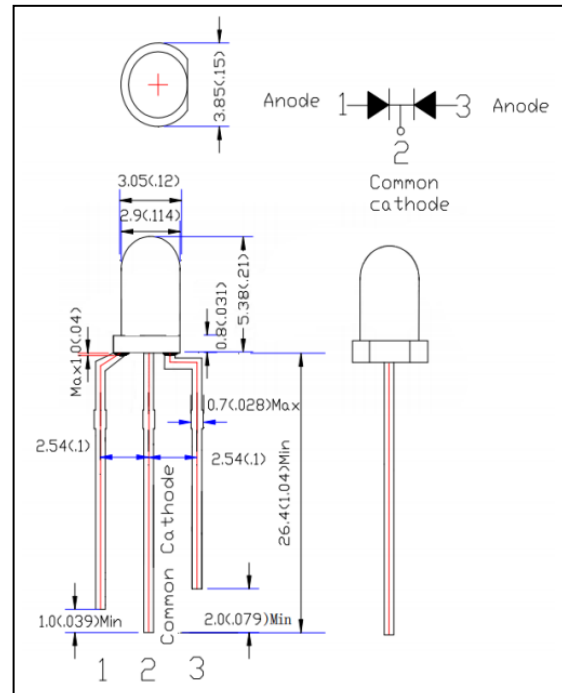

Absolute Maximum Ratings (Ta=25°C)

Parameter	Max.	Unit.
Peak Forward Current (1/10 Duty Cycle, 0.1ms Pulse Width)	100	mA
Continuous Forward Current	20	mA
Reverse Voltage	5	V
Operating Temperature Range	-40 °C to +85°C	
Storage Temperature Range	-40 °C to +100°C	
Lead Soldering Temperature [4mm (.157") From Body]	250°C for 5 Seconds	

Electrical and optical characteristics

Parameter	Symbol	Typ.	Unit.	Test Condition
Luminous Intensity	I_v	R=19 / G=19	mcd	I_f =(mA) R=20 / G=20
Viewing Angle	$2\theta_{1/2}$	75	deg.	
Dominant Wavelength	Δd	R=630 / G=565	nm	